



⚠ DANGER

⚠ DANGER

PCP Well Manager™

Optimize Your
Progressing Cavity Pump

Getting the Most Out of Your Well

- Integrated system maximizes production
- Automatically monitor and adjust pump speed
- Protect against pump off

Bringing Solutions to Surface



Control Your Progressing Cavity Pump

KUDU and Lufkin Automation have joined forces to offer an innovative system for maximizing performance in PCP wells. KUDU's smart well technology seeks and detects hidden production points to ensure your well is always running at optimum levels. The PCP Well Manager optimizes production by measuring flow rates, monitoring torque and adjusting pump speed. The data is logged in real time and enables you to view and implement changes remotely. Anytime and anywhere.

Optimize Your Well

There are several problems associated with maintaining a safe fluid level while using manual fluid level equipment. Fluid levels are an indicator of how much fluid is over the pump at the time the fluid level is taken. Fluid levels are constantly misinterpreted due to surface, rod noise and foam. Downhole anomalies such as high liner tops, bad dog legs or other "non standard" configurations will result in false fluid level data. It is extremely time consuming to shoot fluid levels, adjust speed and then allow the well to stabilize and shoot the fluid level again. This manual process does not react quickly enough to changes in inflow.

The PCP Well Manager eliminates fluid level monitoring problems and actually increases overall production by keeping the fluid at or near the pump. The system sustains optimum fluid inflow by maintaining the lowest bottom hole pressure possible. The PCP Well Manager's ability to pump over capacity empowers the system to recovery quickly from downtime.

Reduce Premature Pump Failure

Controlling PCP's reduces premature pump failures due to pump off. Pump off is defined as a lack of fluid in the pump and it leads to stator damage. This lack of lubrication creates a rise in temperature and ultimately burns the elastomer in the pump. The rubber surface of the stator becomes hard, brittle and cracked. In severe circumstances; the stator contour is completely torn up producing rubber at surface. Plugged pump intake, poor inflow or production rates exceeding inflow are typically to blame.

Lufkin Automation PCP Algorithm

The PCP control algorithm is the brains of the system. Its primary purpose is to optimize well production without causing pump off. This patented control algorithm varies the speed of the pump in steps while measuring fluid production. As long as sufficient fluid is available at the pump intake to completely fill the pump cavities, a linear relationship occurs between fluid production and pump speed. This hunting algorithm is always searching for the most production. The PCP Well Manager continues to increase pump speed in user-defined steps and measures the production rate, after the settling time, of each step to establish an optimal speed/rate relationship.

The PCP Well Manager Advantage:

- Reduce pump off
- Efficiently monitor fluid levels
- Optimize your well
- Analyze data and make changes remotely
- Yield better results

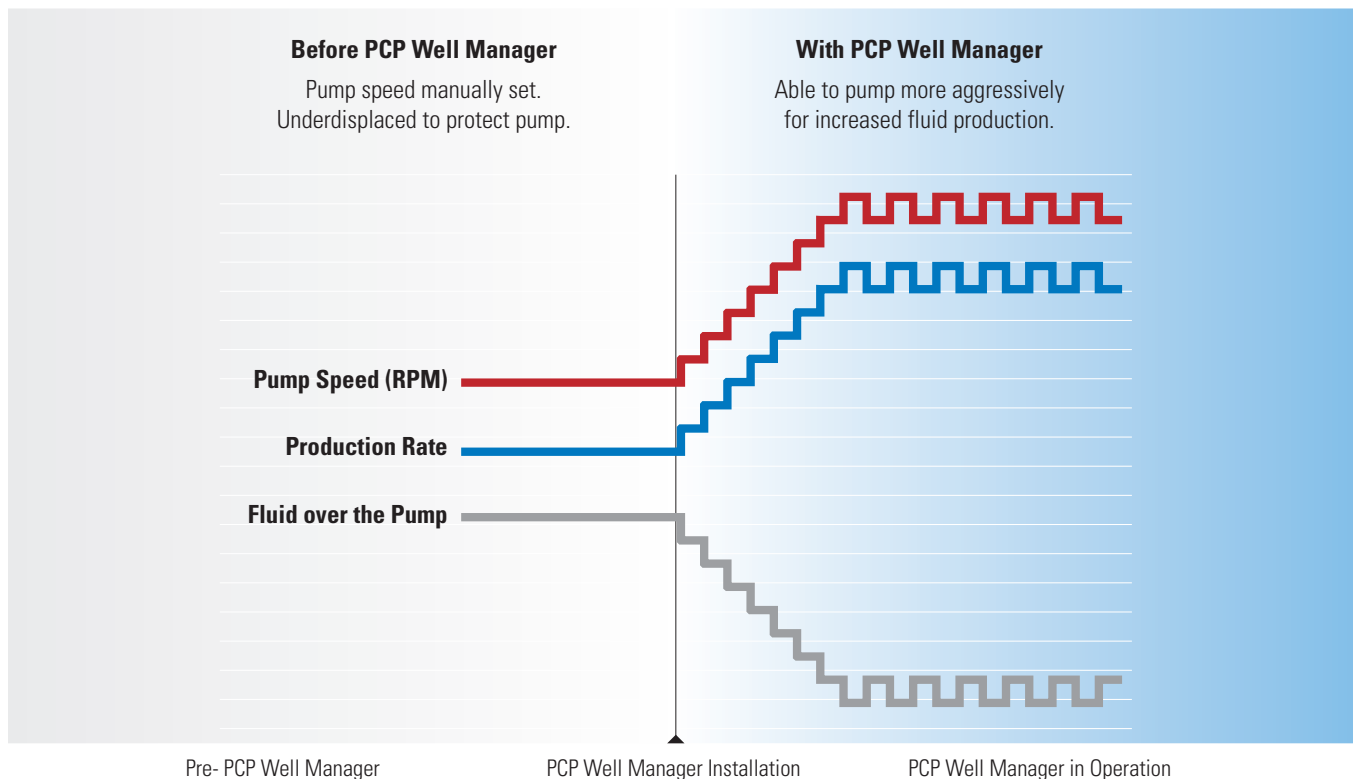

Proven Performance

Case Study 1

A 15 well pilot project started in January 2007 included the host SCADA system and the PCP VFD Combo unit complete with wedge flow meters. The results showed an increased average oil production from 120 m³/day, to 145 m³/day. An unexpected benefit of increased average gas production from 19 to 23 Dec/day was also noticed. This showed an estimated payout in 120 days. The graph to the right shows the result from 1 of the 15 wells in the pilot project.

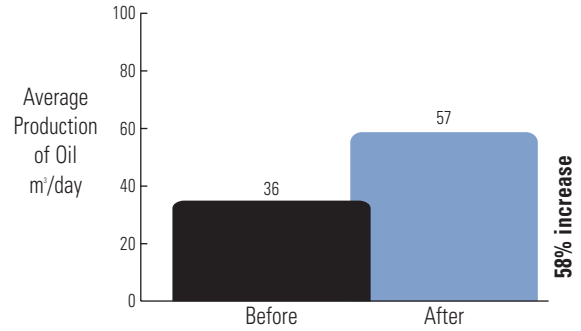

Case Study 2

A single well pilot started in December 2009 was chosen due to its inability to keep running. Before optimizing the well the concentration was on producing the sand that was preventing the well from operating. By bringing the well on slowly and limiting the maximum speed over four stages the sand was cleaned up to a very manageable level. The revenue for the well increased from \$0/day to \$7,798/day with an oil gain of 19.4 m³/day.

	NOV 26- DEC 26/09 Pre-Controller #1	DEC 27- MAR 15/10 Post-Controller #1	MAR 16- APR 15/10 Post-Controller #2	APR 15- MAY 15/10 Post-Controller #3	MAY 16- JUNE 15/10 Post-Controller #4
Hrs On	744	741	744	744	744
m ³ Oil/Day	0.00	0.99	1.29	10.19	19.40
m ³ Sand/Day	0.000	0.006	0.000	0.000	0.000
m ³ H ₂ O/Day	48.97	38.45	108.95	139.40	144.30
m ³ Oil/Day	0.00	0.99	1.29	10.19	19.40
\$/Day	\$ 0.00	398.11	517.41	4,097.81	7,798.80
\$/Month	\$ 0.00	12,341.40	16,039.80	127,032.00	241,762.80

Case Study 3

A single well pilot started in July 2008 was chosen due to its extreme production difficulties. For the first six months prior to the installation of the PCP controller, this Bakken zone well had four pump changes due to sand and inflow issues. The well produced a total of 2711 m³ with an operational cost of \$198,000.

On July 1, 2008 KUDU installed a 60 K 1200 pump and added the hydraulic PCP controller with wedge flow meter. For the next six months the well produced 19,779 m³ with no work overs. The pump ran for 14 months before it needed to be changed out due to wear and tear from abrasion. The hydraulic control system expertly maintained speed changes using PID loop control on the proportional valve without adding heat to the system.

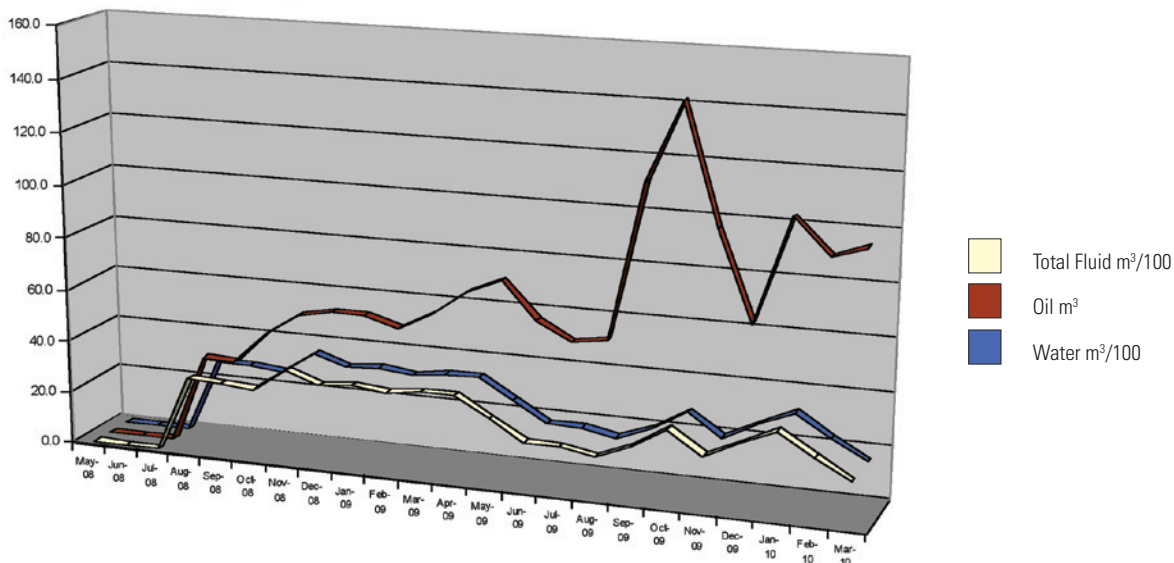



Key Benefits

- Optimize well production
- Protect against pump off
- Provide torque protection
- Log historical data
- Analyze well data and performance
- User-friendly keypad & display

Web Based SCADA System

The PCP Well Manager's data logging provides real time centralized information. The Well Manager uses a Supervisory Control and Data Acquisition system (SCADA). This diagnostic tool enables the user to view and implement changes remotely.

Combining this automation technology and SCADA system has resulted in the development of several data trends and the discovery of additional control algorithms. KUDU is continually developing these algorithms to enhance oil recovery.

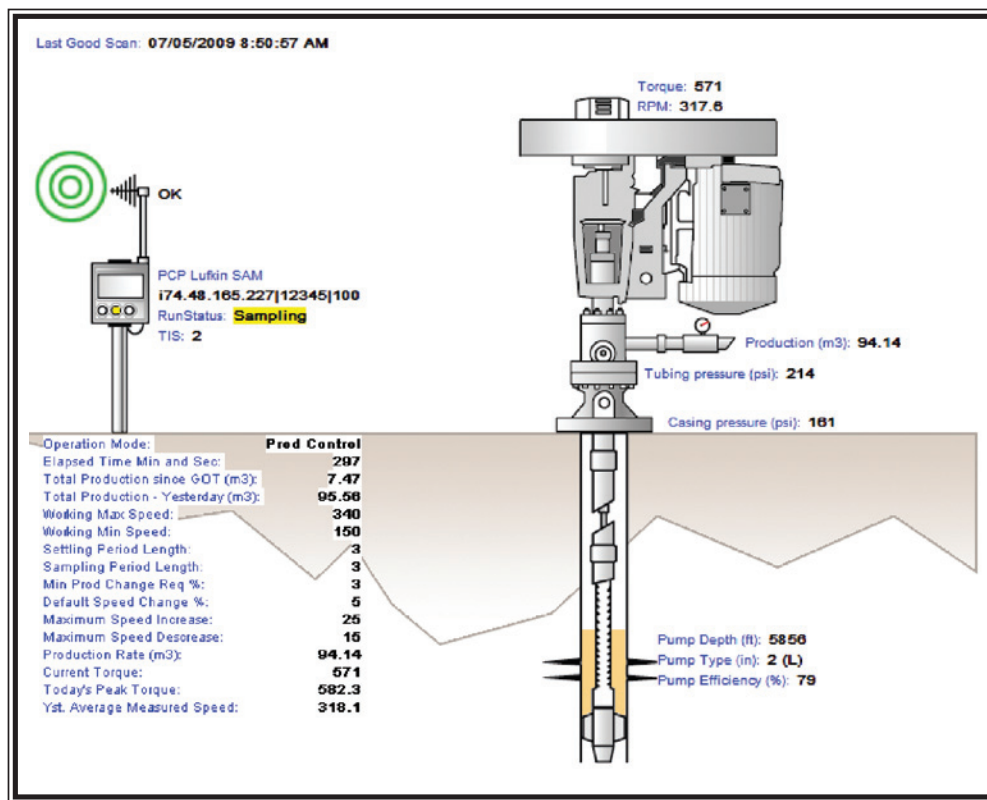

PCP WELL MANAGER



Contact your local KUDU representative or visit our website to find a distributor near you. All information is considered accurate and up to date at time of printing. KUDU reserves the right to amend the contents of this document at any time. KUDU does not warranty manufacturers claims. PCP Well Manager is a trademark of Lufkin Automation.

Bonnyville 1-780-826-7179	Elk Point 1-780-724-2910	Kindersley 1-306-463-6440	Macklin 1-306-753-2950	Sedgewick 1-780-384-2177	Swift Current 1-306-741-2416	Wabasca 1-780-891-1032	KUDU Industries 9112 - 40 th Street SE Calgary, AB Canada T2C 2P3
Brooks 1-403-793-8080	Estevan 1-306-634-9966	Lloydminster 1-780-871-0660	Peace River 1-780-624-9570	Slave Lake 1-780-849-5650	Taber 1-403-223-1201	North America 1-800-642-5519	1-403-279-5838

www.kudupump.com